

Installation & Operating Instructions

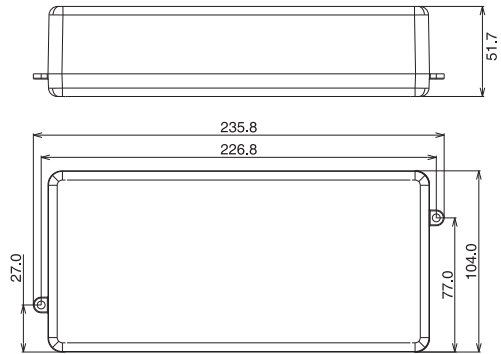

- Following a full discharge, 24 hours should be allowed for the batteries to re-charge.
- The green LED charge indicator signifies that the batteries are charging and will remain illuminated when the luminaire is switched off.
- The batteries have a rated service life of 4 years and should be checked and considered for replacement at that point.

- A record of routine testing should be kept to ensure emergency luminaires are maintained and operated correctly.
- The battery has a 4 year service life provided it is operated and maintained by regular testing, as detailed in this document, Failure to maintain or change the battery may result in reduced duration in emergency mode.

SPECIFICATIONS

- Suitable for use with Mains voltage of 100-240VAC 50/60Hz
- This product must be disconnected before insulation resistance testing of the lighting circuit
- Check for electrical cables and pipes before installation

NOTE - To comply with regulations, Installation must be carried out by suitably qualified competent person and in accordance with the current IEE Wiring Regulations (BS7671) and Building Regulations. The Emergency pack requires 2 Live feeds, 1 to charge the battery pack and 1 for switching of the product.

INSTALLATION-NON DIMMING

Turn OFF power supply, ensure all required equipment and tools are present. The Emergency Pack is supplied pre-wired for easy connection to luminaires and drivers.

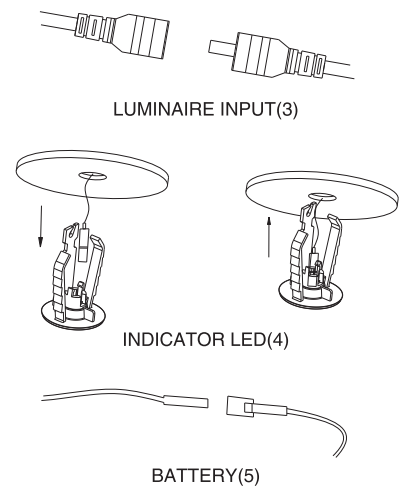
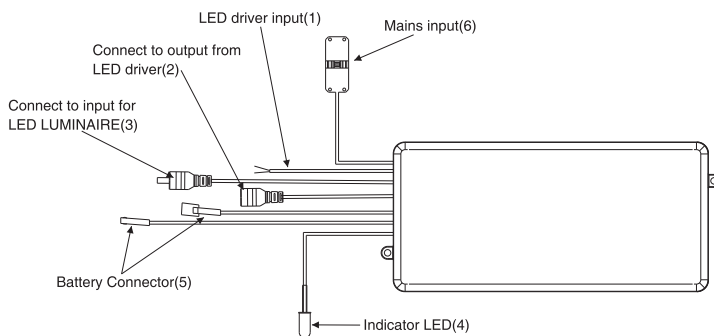

CONNECTING THE DRIVER(1&2)

The emergency pack is supplied pre-wired for connection to the LED driver supplied with the luminaire. Use the L/N cable from the emergency pack(1) as the input for the LED driver, and connect the pre-wired connector from output of the driver to input for emergency pack(2). Remove Safety covers before installation.

LUMINAIRE INPUT(3)

Connect the lead from emergency pack to the connector on luminaire.

INDICATOR LED(4)

Drill a 18mm hole close to the installation location of the luminaire. Feed the indicator cable through the cut-out, insert into the housing then push both into the ceiling until secure.

BATTERY(5)

Push the battery connector together, ensuring correct polarity. do not force plug. NOTE - the luminaire may illuminate due to any stored battery charge.

MAINS INPUT(6)

The emergency pack requires a permanent, switched live and neutral. Earth is not required as the case is Class 2, but provision has been given for a loop through for earth. Connect to 4 way connection block as per labelled.

ENSURE ELECTRICAL SUPPLY AND BATTERY CONNECTION IS DISCONNECTED/ISOLATED BEFORE COMMENCING INSTALLATION OR ANY MAINTENANCE WORK. HIGH VOLTAGE COULD BE PRESENT AT THE OUTPUT CONNECTION IF THE BATTERY IS NOT DISCONNECTED.

WARNING - AVOID RUNNING THE LED MAINS DRIVER AND EMERGENCY PACK WITHOUT THE LOAD CONNECTED. FAILURE TO DO SO MAY RESULT IN DAMAGE TO THE LED EMERGENCY PACK.