

LED Panel Down Light – 10W

with Built-in Driver



3 COLOUR ADJUSTABLE

Model: RDL-1090-3C

S-tech's LED down lights are a direct replacement for halogen down lights. Easy to install and will work with most trailing edge or universal dimmers. Our panel light is designed so there is no requirement for down light canisters to be used with this product.



Product Features

- Only consumes 10w of power
- 3 colours in one 3000K, 4000K and 5000K (switch select)
- Supplied with 2 pin AC plug and cable
- Dimmable with S-Tech, Clipsal or HPM Dimmers
- 100° Beam Angle
- 90mm Cut-Out
- White Trim (optional Brushed Chrome trim attachment available)
- No down light canister required
- 5 Year* Replacement Warranty

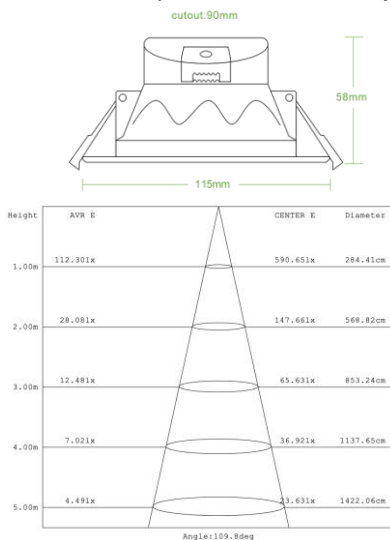

Option: Brushed Chrome Trim Attachment



Model: RDL-BCTRIM

SPECIFICATION

Colour	Warm White (3000K)	Neutral White (4000K)	Cool White (5000K)
Lumen (lm)	850	890	900
Efficiency (Lm/w)	>85Lm/w		
Light Source	SMD LED		
Beam Angle	100°		
Power Requirement	AC 200~240V		
Power Consumption	10W		
Dimmable	Yes		
Housing	Thermo Nylon and Aluminium Alloy		
Lifespan	> 50,000 hours		
Operation Temperature	-25°C~+60°C		
Dimension (mm)	115 (D) × 58 (H)		
Protection Rating	Indoor		
Warranty	5 Years*		

*5 year warranty for residential installations only, 2 years warranty on commercial installations