



60w MultiFiT V3 LED Street Light

Product Features

- 60w
- 2 Colour Adjustable (4000K/5000K)
- Fits 50~60mm spigot size
- Quality Driver
- Full range power input 90~305VAC
- 10KV surge protector
- Aluminium die cast housing
- Supports pole top (90° ±15°) or spigot mounting (0° ±15°)
- 150/80° Beam Angle
- PE cell compatible
- IP65 Housing
- IK08 Impact Rating
- Weight: 4.8kg



2 Colour Adjustable

Options:



PE Cell



Mounting Poles



Ø32-40mm Spigot Replacement

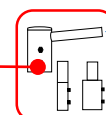

Outreach or Spigot Adaptors



Spigot mounting



Pole top mounting

Specification Overview



Model	Power	Power Requirement	Colour Temp	Lumens	Beam Angle	Trim Colour	Dimensions	Spigot Size
SLM-060W-2C	60w	90~305VAC	4000K/ 5000K	6662lm/ 6725lm	150/80°	Black	568x200x109mm	50~60mm

Product Specification



60w MultiFiT V3 LED Street Light

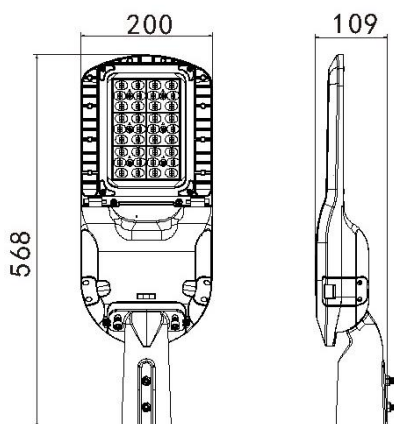

Specification

Model	SLM-060W-2C	
Colour Temperature (2CCT)	4000K	5000K
Lumen (lm)	6662lm	6725lm
Efficiency (lm/w)	>115lm/w	>116lm/w
Light Source	LED	
CRI (%)	≥80	
Beam Angle	150° / 80°	
Power Requirement	90~305VAC	
Power Consumption	57.5w	
Dimmable	No	
Housing	Diecast aluminium with tempered glass diffuser	
Lifespan	>40,000 hours	
Operation Temperature	-30°C~+40°C	
Product Dimension	568 x 200 x 109mm (Spigot mount)	
Fits Spigot Size	Ø50 ~ Ø60mm	
Impact Rating	IK08	
Weight	4.8kg	
Protection Rating	IP65	
Warranty	5 Years	

Options:



PE Cell
(Model: SLM-PE)



Mounting Poles



Ø32-40mm Spigot Replacement
(Model: SLM-SPIGOT-40)

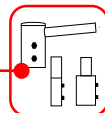

Outreach or Spigot Adaptors

Specifications are subject to change without notice