

Surface mounting

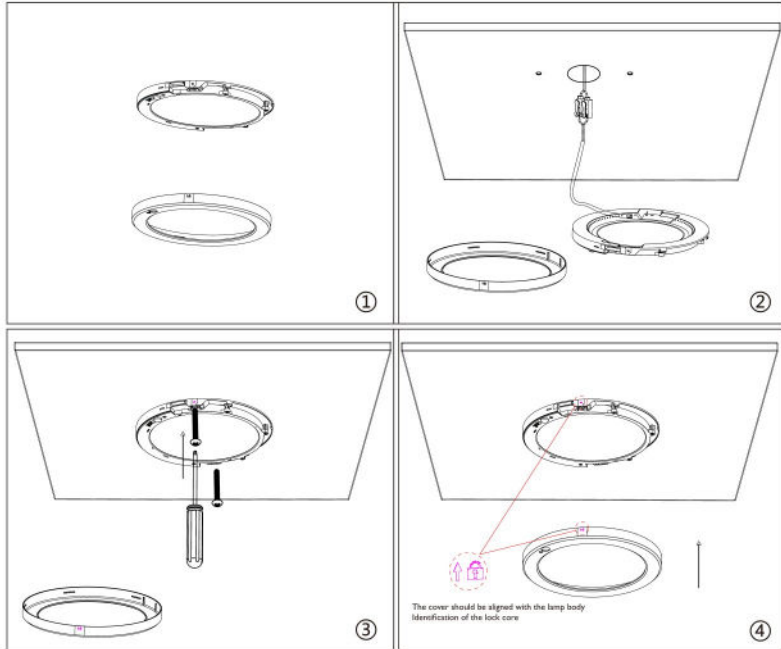

1. Take off surface cover
2. Connect power cable with terminal

3. Use screws fixing light onto roof through light housing holes
4. Install surface cover to light body. Ensure lock marks are matched.

Mounting method of bracket surface mounting

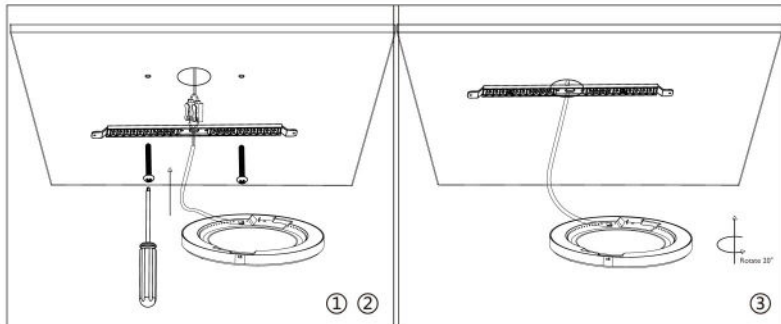

1. Connect power cable with terminal
2. Fix bracket onto ceiling with screws

3. Twist on light to tighten it with bracket

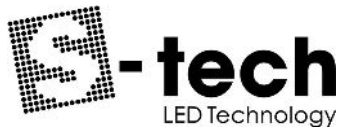

For further information contact
S-Tech Holdings Pty Ltd on 08 9330 8485



SENSE LED Panel Installation Instructions

Model: SENSE-18

Please read these instructions carefully in full prior to carrying out the installation.

IMPORTANT SAFETY ISSUES

- This product must be installed by a qualified electrician according to AS/NZS 3000.
- Ensure that the AC power is disconnected at the switchboard and test to ensure that there is no power on the circuit prior to starting installation.
- This product is rated to IP20 and is not suitable for damp environments.
- Modification of this product will void any warranty.
- When cleaning or replacing the light, please ensure the power is off and the light is completely cooled down. Cleaning can be done using a soft cloth and PH neutral detergent.

INSTALLATION INSTRUCTIONS

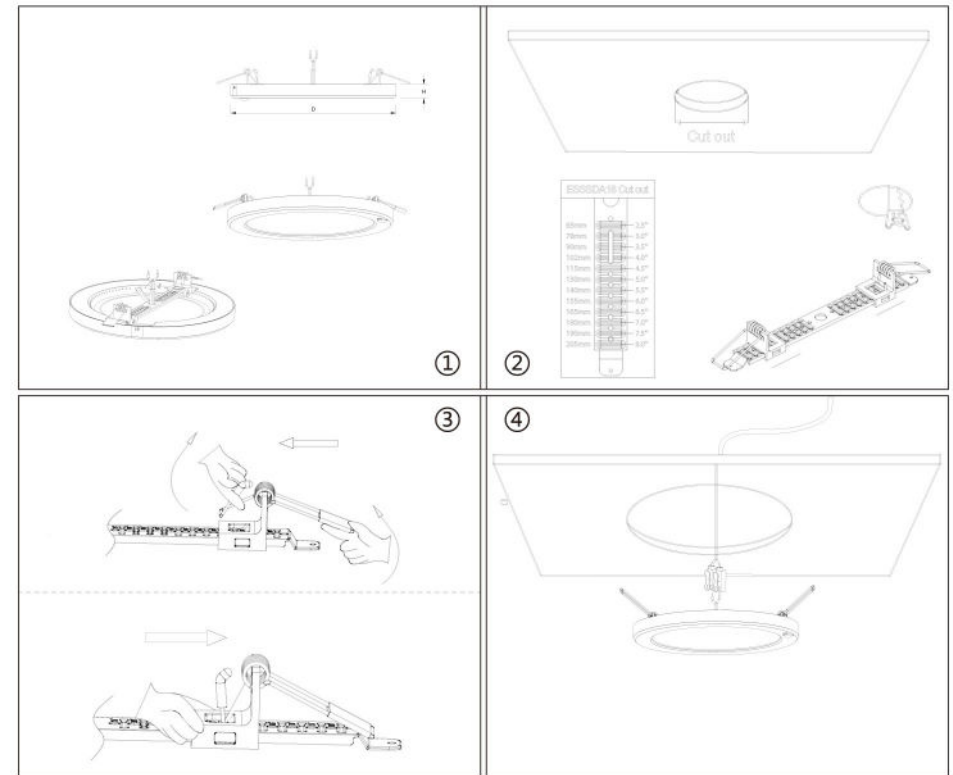

1. Adjust springs to suitable size position according to ceiling cut-out
2. Twist on bracket into light;

3. Connect power cable with terminal
4. Pull up springs, install light into ceiling cut-out

Note: for surface mount instructions, please refer to the back page of this instruction manual